

Rated Load	410kg
Supply	415v, 3ph, 16 amp Type C, 30mA RCB0 protected
Running Current	4.7 amps
Starting Current	18 amps
Platform Size	1000 wide x 1280 deep

Pit	50 deep
Door Level 0	GL Non Fire Rated
Door Level 1	GL Non Fire Rated
Door Level 2	N/A
Communication	Telephone/Autodialer

Enclosure Colour	RAL 9003
Door Colour	RAL 9003
Door Frame Colour	RAL 9003

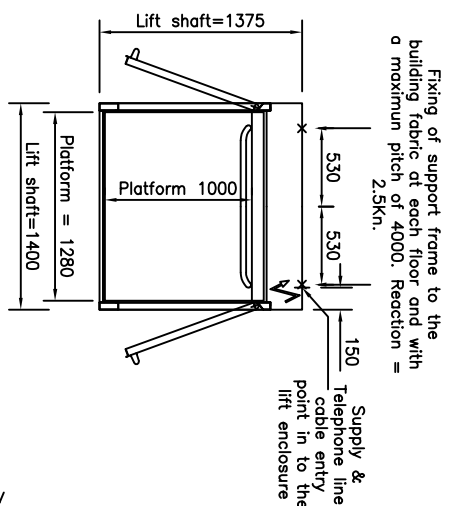
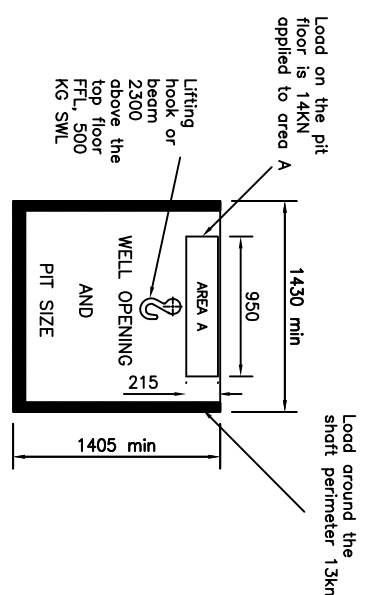
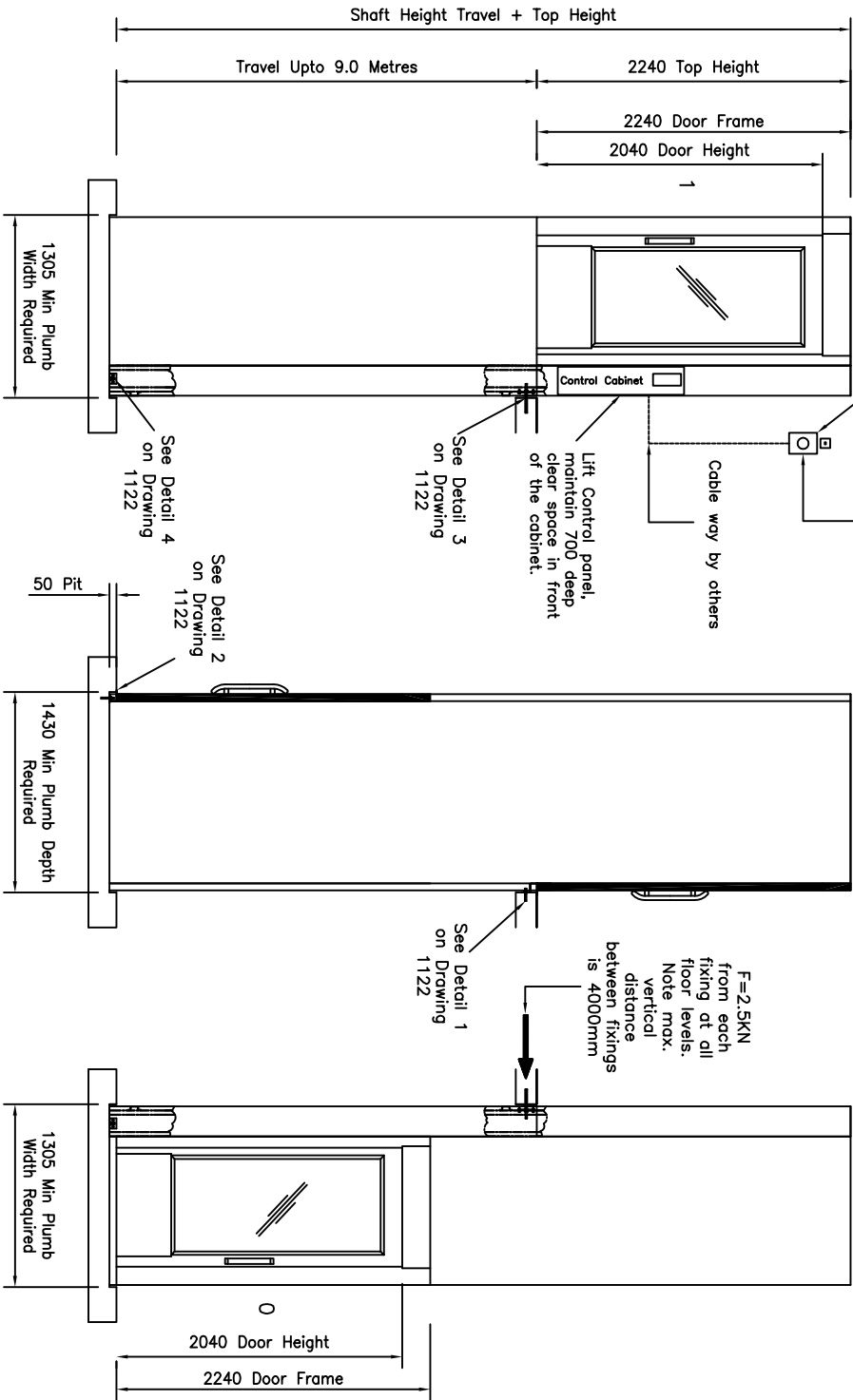

SEE DRAWING NO. 1122 FOR A GENERAL LIST OF WORKS BY OTHERS.

Issued for information only

BY	DATE	ISSUE	CHECKED
TMP	04.13	B	
MODIFICATION		Re drawn	

PLATFORM LIFT STANDARD LAYOUT
THROUGH ARRANGEMENT WITH 1000 x 1280 PLATFORM STEEL ENCLOSURE

NICHE LIFTS Ltd		DRAWN BY	DATE	CHECKED	SCALE
Do not scale this drawing. All dimensions in millimetres		TMP	31.10.06		
NICHE LIFTS LTD Suite 3, 27 London Road, Bromley, Kent, BR1 1DG Tel: 020 8296 2862 Fax: 020 8466 1695 e-mail: contracts@nichelifts.co.uk Web Site: www.nichelifts.co.uk		DRAWING NUMBER		1166/B	