

Specification

1000 x 800 mm Platform

Front Access

Rated load 225 kg

Speed 0.1 m/s

Supply: Single phase 220 VAC

Carriage Colour: RAL 7035

Rail finish anodized aluminum

Wall Mounted

20-50 degree stair angle

Electrical components rated to IP65

Control units at both landings incorporate

Up/Down, barrier and platform position constant pressure controls.

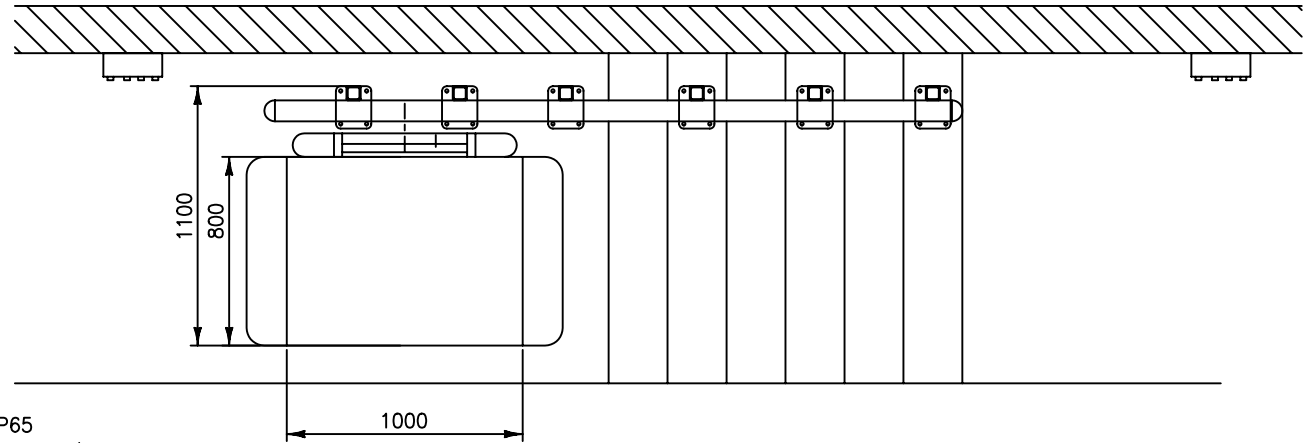

Shear
3.75 kn

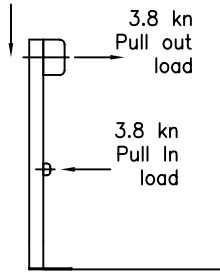

FIXING RAIL REACTIONS

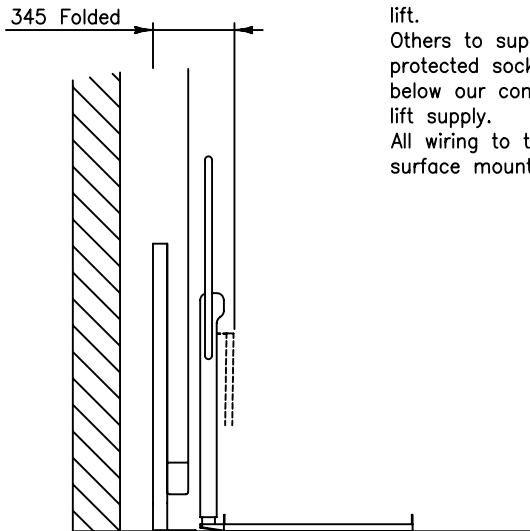

Notes

Others to ensure that the fixing wall can withstand the loads from the platform lift.

Others to supply a 13 amp RCD protected socket outlet at the top landing below our control unit for the platform lift supply.

All wiring to the control units to be surface mounted.

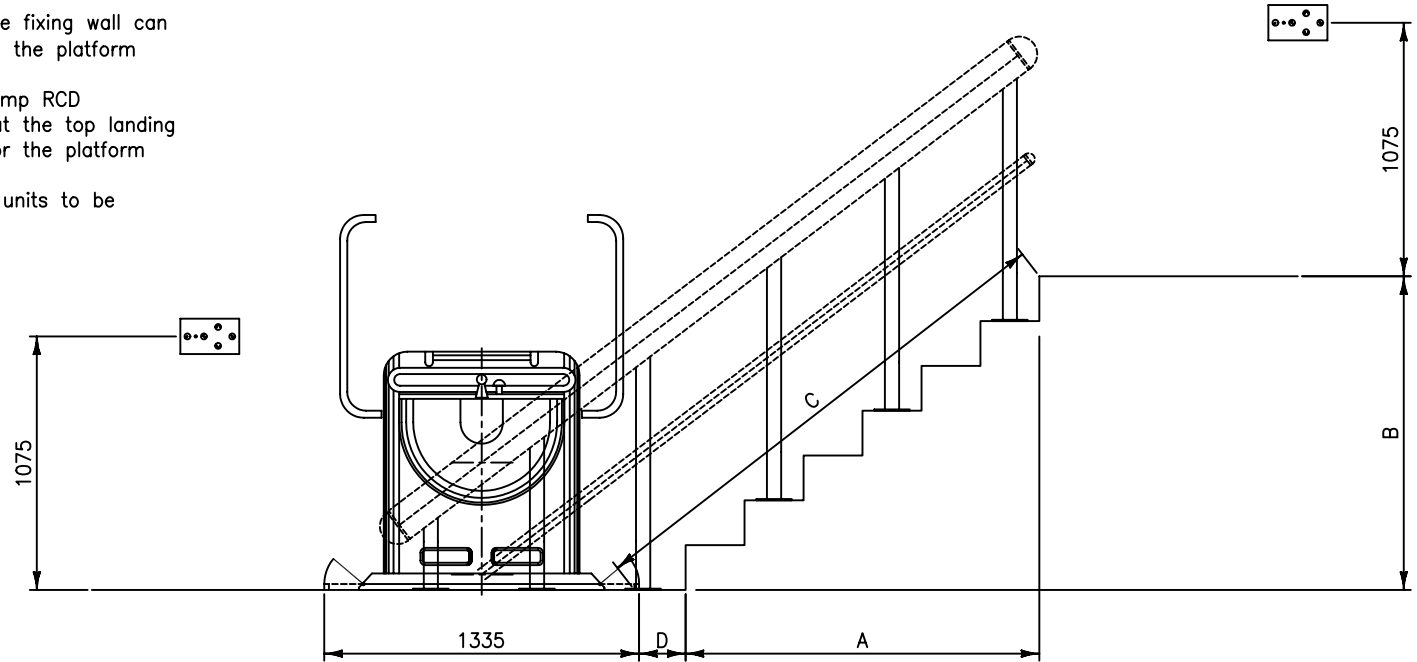

BY	DATE	ISSUE	MODIFICATION	CHECKED

INCLINED PLATFORM LIFT 1000 X 800 PLATFORM GENERAL ARRANGEMENT STANCHION MOUNTED LEFT HAND
(Issued for information only)

NICHE LIFTS Ltd
Do not scale this drawing. All dimensions in millimetres

DRAWN BY	DATE	CHECKED	SCALE
TMP	2.5.07	FWP	1:25
DRAWING NUMBER			
1177/A			