

Specification

1000 x 800 mm Platform  
 Front Access  
 Rated load 225 kg  
 Speed 0.1 m/s  
 Supply: Single phase 220 VAC  
 Carriage Colour: RAL 7035  
 Rail finish anodized aluminum  
 Wall Mounted  
 20-50 degree stair angle  
 Electrical components rated to IP65  
 Control units at both landings incorporate  
 Up/Down, barrier and platform position  
 constant pressure controls.

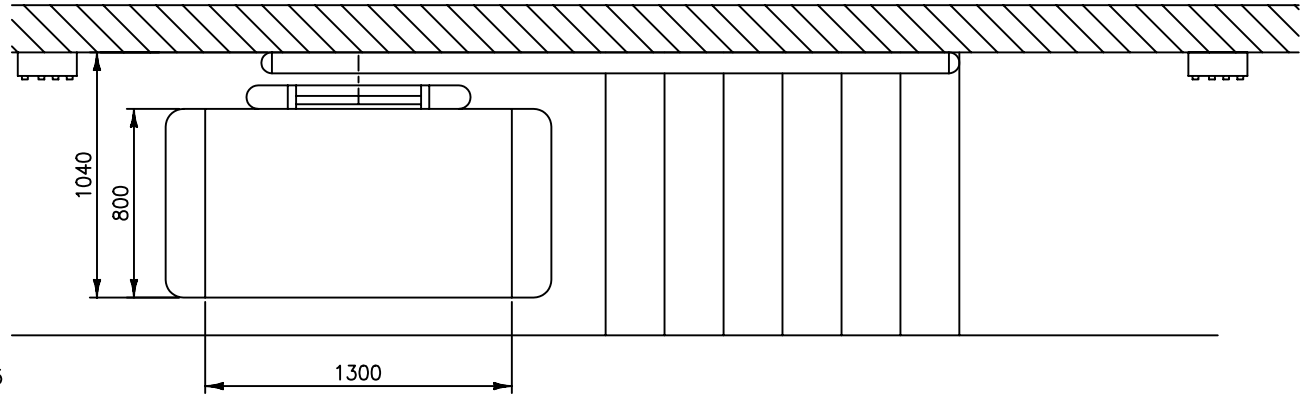

FIXING RAIL REACTIONS

Notes

Others to ensure that the fixing wall can withstand the loads from the platform lift.  
 Others to supply a 13 amp RCD protected socket outlet at the top landing below our control unit for the platform lift supply.  
 All wiring to the control units to be surface mounted.

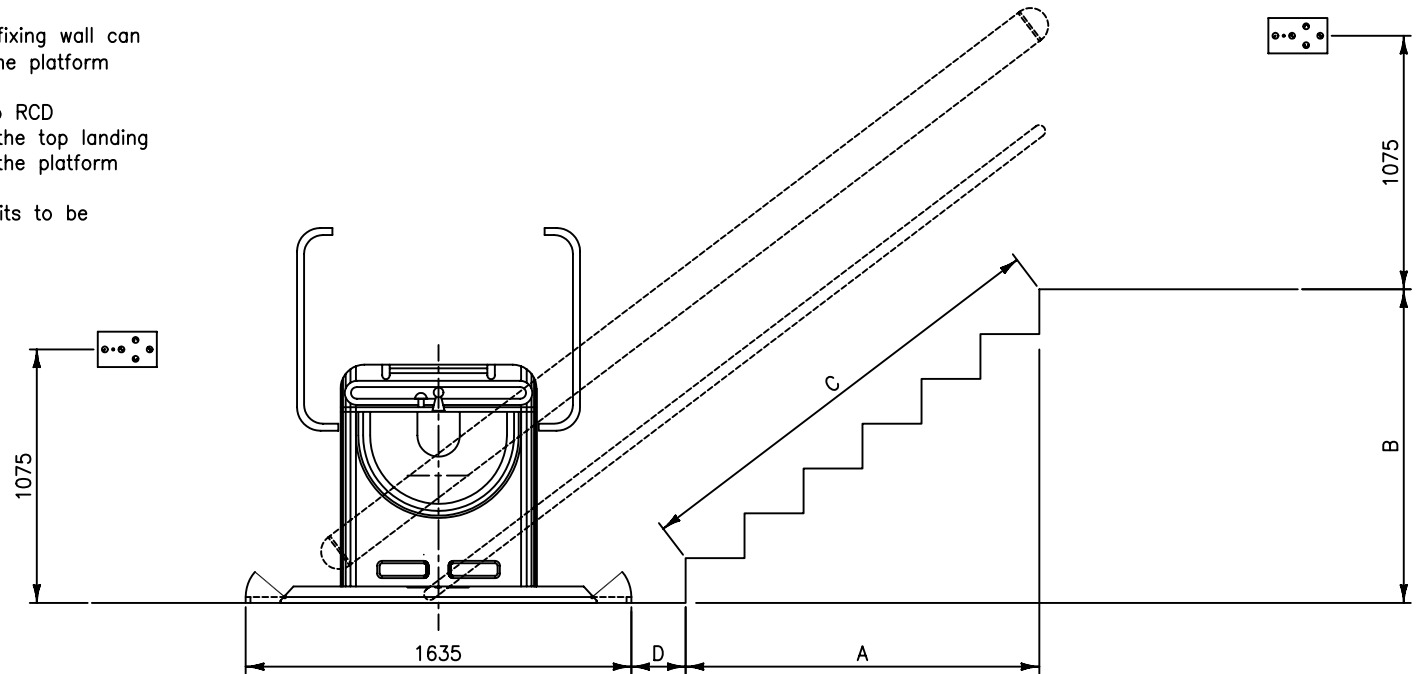
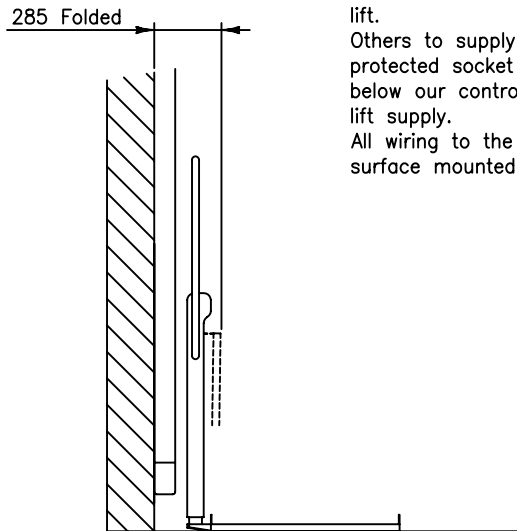

BY	DATE	ISSUE	MODIFICATION	CHECKED

INCLINED PLATFORM LIFT 1300 X 800 PLATFORM GENERAL ARRANGEMENT LEFT HAND  
 (Issued for information only)

**NICHE LIFTS Ltd**

Do not scale this drawing. All dimensions in millimetres

DRAWN BY	DATE	CHECKED	SCALE
TMP	3.5.07	FWP	1:25

DRAWING NUMBER

1180/A